

EE462L, Power Electronics, Capacitor Filtered Diode Bridge Rectifier

Version Sept. 2, 2011

Overview

Electronic loads, such as desktop computers and televisions, operate on DC rather than AC. However, power is distributed in the U.S. through a 60Hz AC system. Electronic loads have a capacitor filtered, diode bridge rectifier that converts the incoming AC to DC. Later, we will learn how to efficiently reduce rectifier V_{dc} outputs to more useable values such as $12V_{dc}$.

The rectifier circuit that you and your partner build will be used many times during this semester and in future semesters. Combined with the $25V_{ac}$ transformer source, it will produce approximately the same $36-40V_{dc}$ that solar panel pairs on the ENS roof produce. **So, please build a neat, rugged circuit that will last, and solder your connections properly!** When finished, neatly print your team member names on the wood with a dark pen or permanent marker **for all to see clearly.**

Important

Do not energize your circuit until it has been inspected by Dr. Grady or one of the TAs. Carefully check the polarity of the diode bridge and capacitor carefully – **electrolytic capacitors can explode if they are reverse biased.** You will connect $28V_{ac}$ to your DBR.

Basics of Circuit Operation

The basic components of the single-phase rectifier are four diodes and a large electrolytic capacitor. The four diodes are often packaged together as one four-terminal device. The diodes rectify the incoming V_{ac} , and the capacitor smoothes the peak-to-peak ripple voltage in V_{dc} to a reasonable value (e.g., 5-10% of peak V_{dc}).

The basic rectifier circuit is shown below in Figure 1. When V_{ac} is positive, diodes 1 and 2 conduct, while diodes 3 and 4 are reverse-biased and open. When V_{ac} is negative, diodes 3 and 4 conduct, while diodes 1 and 2 are reverse-biased and open.

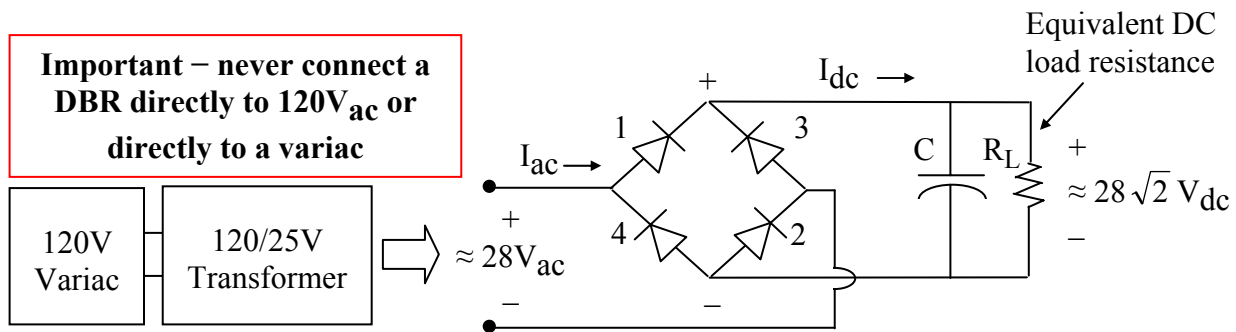

Figure 1. Single-Phase Diode Bridge with Capacitor Filter

EE462L, Power Electronics, Capacitor Filtered Diode Bridge Rectifier

Version Sept. 2, 2011

Important note on safety: There are two hazards if you connect a variac directly to a DBR. First, and most important, is because when using a variac it is very easy to accidentally apply more than $35V_{ac}$ to the DBR, which when rectified exceeds the 50V rating of the capacitor. If you accidentally apply $120V_{ac}$, then the capacitor voltage can reach 165V! The capacitor can rupture or explode when severely overvoltaged, and the circuit breaker inside the variac may not prevent this from happening.

Second, the variac does not isolate the power ground from the load. Thus, when you touch the variac "hot" output, you can get a shock. But if you use a dual-winding transformer, like the 120/25 transformers in the lab, then the output has no ground reference. With no ground reference, you can still get shocked, but you must contact both terminals of the transformer output for this to happen.

To better understand the operation of the circuit, imagine that the capacitor is removed. Diodes 1 and 2 conduct when $V_{ac} > 0$. Diodes 3 and 4 conduct when $V_{ac} < 0$. The resulting voltage waveforms with $V_{ac} = 28V$ are shown in Figure 2.

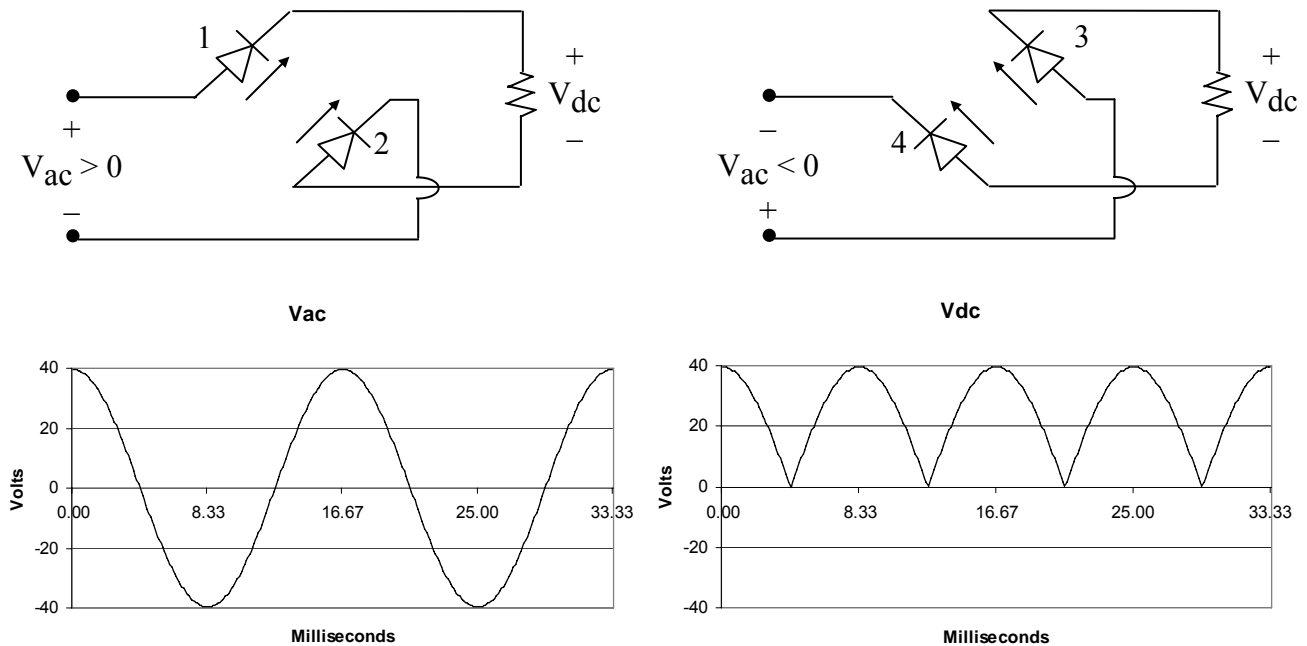

Figure 2. AC and DC Voltage Waveforms with a DC Load Resistor and No Capacitor

EE462L, Power Electronics, Capacitor Filtered Diode Bridge Rectifier

Version Sept. 2, 2011

The addition of capacitor C smooths the DC voltage waveform. If time constant $R_L C$ significantly exceeds $\frac{T}{2}$, where $T = \frac{1}{f}$, then the capacitor provides load power when the rectified AC voltage falls below the capacitor voltage. As simulated by Excel program EE362L_Diode_Bridge_Rectifier.xls for the case shown below,

F - Hz	C - uF	VAC	P - W
60	18000	28	200

the waveform for V_{dc} takes the form of V_{cap} in Figure 3.

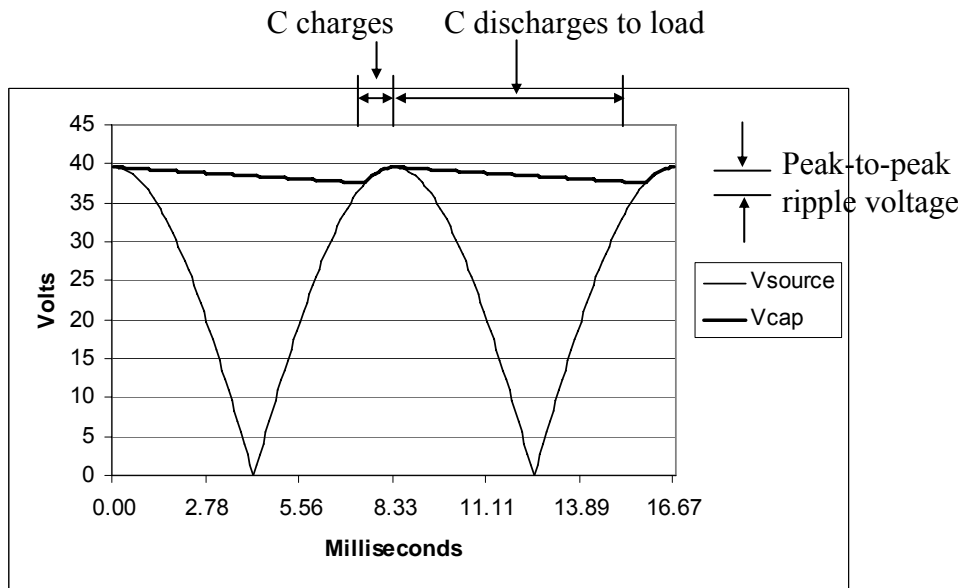

Figure 3. Impact of C on Load Voltage

As the load power increases, the capacitor discharges faster, the peak-to-peak ripple voltage increases, and the average dc voltage (i.e., the average value of the V_{cap} curve in Figure 3) falls. For zero load, V_{cap} remains equal to the peak of the rectified source voltage, and the ripple voltage is therefore zero.

Current and power flow from the AC side only when C is charging. When not charging, the voltage on C is greater than the rectified source voltage, and the diodes prevent current from flowing back into the AC side. Thus, AC current and power flow into the circuit in relatively short “bursts.” As load power increases, the width of the current bursts becomes wider and taller, as illustrated in Figure 4. The precise shape of the current pulse depends on system impedance. If the impedance is mainly resistive, the current pulses resemble the top portions of sine waves. Inductance in the system impedance causes a skewing to the right.

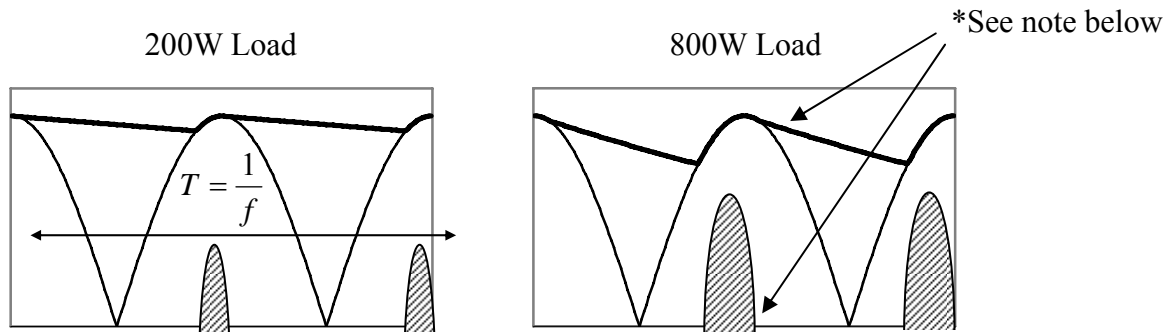

Figure 4. DC-Side Current i_{dc} for Two Different Load Levels
(This figure shows how the average voltage to the load drops as load power increases.
This phenomenon is due to the capacitor action and is not due to DBR resistance.)

* Inductance in the power system and transformer will cause the current to flow after the peak of the voltage curve. In that case, the capacitor voltage will follow the rectified voltage wave for some time after the peak. The higher the power level, the longer the current flows.

Reflected to the AC-side, the current is alternating with zero average value and half-wave symmetry, as shown below in Figure 5 for the 200W example.

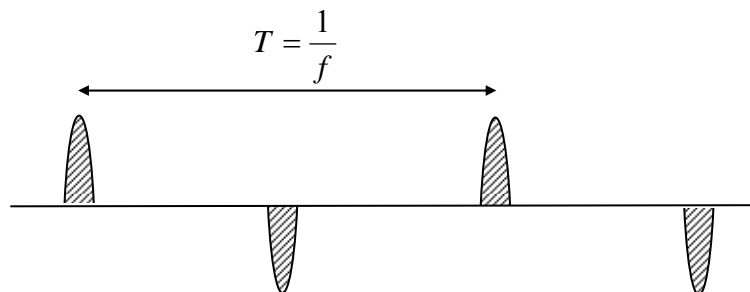

Figure 5. AC-Side Current I_{ac}

Estimation of DC Ripple Voltage for Constant Power Loads

Most power electronic loads require constant power. Thus, representing the load as a fixed resistor, as shown in Figure 1, is not exactly correct.

For constant power cases, peak-to-peak voltage ripple can be computed using energy balance in the capacitor as follows. If the “C discharging” period in Figure 3 is Δt , where $\frac{T}{4} \leq \Delta t \leq \frac{T}{2}$, then the energy provided by C during Δt is

$$\frac{1}{2} C (V_{peak}^2 - V_{min}^2) = P \Delta t, \quad (1)$$

EE462L, Power Electronics, Capacitor Filtered Diode Bridge Rectifier
Version Sept. 2, 2011

where V_{peak} and V_{min} are the peak and minimum capacitor voltages in Figure 3, and P is the DC load power (approx. constant). From (1),

$$V_{peak}^2 - V_{min}^2 = \frac{2P\Delta t}{C} .$$

Factoring the quadratic yields

$$(V_{peak} - V_{min})(V_{peak} + V_{min}) = \frac{2P\Delta t}{C} , \text{ or.}$$

$$(V_{peak} - V_{min}) = \frac{2P\Delta t}{C(V_{peak} + V_{min})} . \quad (2)$$

At this point, a helpful simplification can be made if, as shown in Figure 6, the following assumptions are made: 1. the AC sinewave of voltage is approximated as a triangular wave, and 2. a straight line decay of voltage.

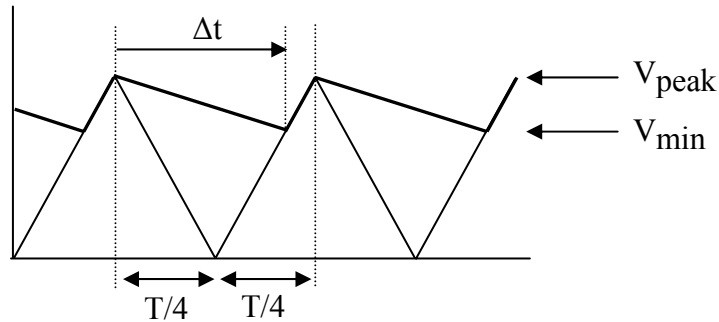

Figure 6. Approximation of Waveform Used for Ripple Calculation Formula

In that case, simple geometry shows the relationship between Δt and $(V_{peak} - V_{min})$ to be

$$\Delta t = \frac{T}{4} + \frac{V_{min}}{V_{peak}} \cdot \frac{T}{4} = \frac{T}{4} \left(1 + \frac{V_{min}}{V_{peak}} \right) , \text{ or}$$

$$\Delta t = \frac{T}{4V_{peak}} (V_{peak} + V_{min}) . \quad (3)$$

Substituting into (3) into (2) yields

EE462L, Power Electronics, Capacitor Filtered Diode Bridge Rectifier

Version Sept. 2, 2011

$$(V_{peak} - V_{min}) = \frac{2P \frac{T}{4V_{peak}} (V_{peak} + V_{min})}{C(V_{peak} + V_{min})} = \frac{PT}{2CV_{peak}} \quad (4)$$

Since $T = \frac{1}{f}$, then the final expression for ripple becomes

$$(V_{peak} - V_{min}) = V_{peak-to-peak\ ripple} = \frac{P}{2fCV_{peak}} \quad (5)$$

For the circuit to be built (using 18mF),

$$V_{peak-to-peak\ ripple} \approx \frac{200}{2 \cdot 60 \cdot 18000 \cdot 10^{-6} \cdot 28\sqrt{2}} = 2.33V \quad .$$

Expressed as a percent of peak voltage, the voltage ripple at 200W load is approximately

$$\%V_{ripple} = \frac{V_{peak-to-peak\ ripple}}{V_{peak}} \approx \frac{2.33}{28\sqrt{2}} \cdot 100\% = 5.88\%$$

The Circuit

The schematic for the circuit that you will build is shown in Figure 7. To maximize effectiveness of the heat sink, make sure that the diode bridge rectifier module has good physical contact with the heat sink and no air gaps in between.

The heat sink should be mounted vertically and held into place by a steel corner bracket so that there is no gap between the heat sink and the wood

EE462L, Power Electronics, Capacitor Filtered Diode Bridge Rectifier
Version Sept. 2, 2011

Be very careful to connect the polarities of the diode bridge and capacitor. These components can be ruined, and capacitors can explode, if their polarities are reversed!

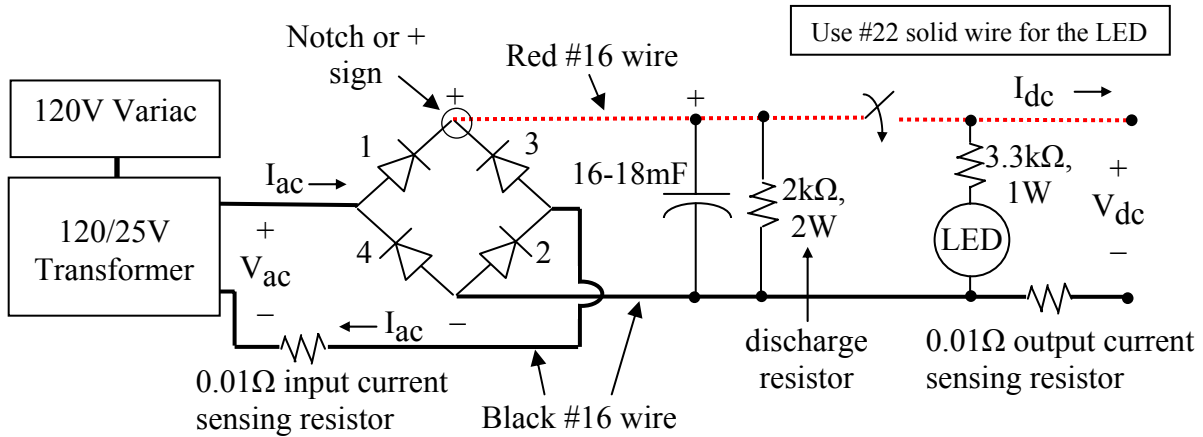

Figure 7. Schematic for Capacitor Filtered Diode Bridge Rectifier

(Note – use the variac to hold $V_{ac} = 28 \pm \frac{1}{2} V_{rms}$ during your experiment. Mount the capacitor vertically. Mount the output switch so that “up” corresponds to the “on” position)

Note – to avoid accidentally shorting the capacitor, never try to measure the voltage directly across the capacitor terminals.

The 2kΩ resistor across the capacitor is a discharge resistor that slowly discharges the capacitor after the circuit is de-energized.

By using the variac to slowly increase input voltage, short circuits or other problems in your circuit can hopefully be identified before damage is done.



Circuit Layout Showing Variac, 25V Transformer, and DBR

EE462L, Power Electronics, Capacitor Filtered Diode Bridge Rectifier

Version Sept. 2, 2011

Regarding the toggle switch – a hex nut goes on the inside of the steel corner bracket, and the lock washer and round nut go on the outside. Mount the hex nut so that it does not touch the body of the toggle switch. That way, when tightening, the pressure is on the hex nut instead of on the body of the toggle switch (see below)

Space left between hex nut and body of switch

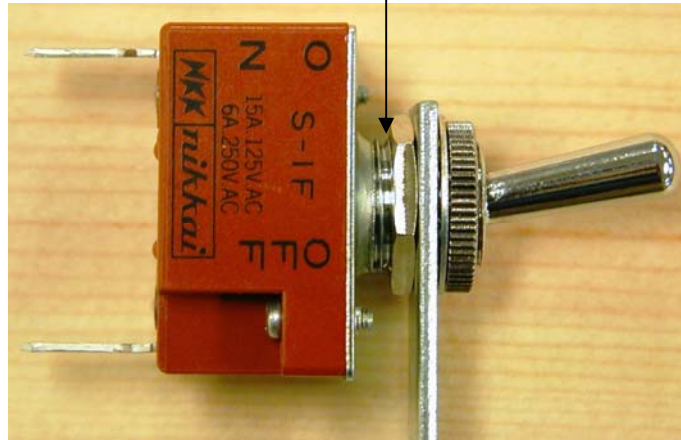

Warning – when connecting quick disconnects to diode bridge rectifier modules and toggle switches, it is very easy to cut your fingers if you are not careful. The proper way is to hold the body of the rectifier module or toggle switch in one hand (or in a vise), and then use your long-nose pliers at a right angle to push the disconnect/wire onto the terminal.

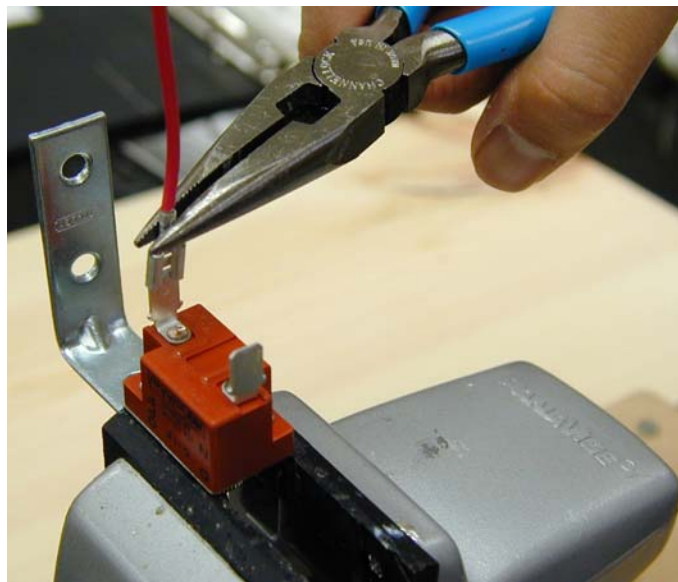

The Experiment

- A. **No Load Conditions.** Connect a 25V transformer to the input of your unloaded DBR. Then, with a **variac turned off and its voltage control knob at zero**, plug the 25V transformer into the variac outlet. Slowly raise the variac to a few volts and make sure that the variac current remains zero. Then, slowly raise the variac so that the **transformer output is $28 \pm \frac{1}{2}$ V_{rms}**. Use a multimeter to measure the “no load” values of V_{ac} and V_{dc}. Make sure you measure V_{dc} at your DBR’s output terminals. View no-load V_{ac} on the oscilloscope. Then, move your oscilloscope probe and view no-load V_{dc} on the oscilloscope. The ripple voltage should be nearly zero. **Note – do not attempt to view V_{ac} and V_{dc} simultaneously on the oscilloscope because they have different ground reference points!**
- B. **Measure the No Load (Ambient) Temperature of the Heat Sink** using a thermistor (see resistance-temperature characteristics in Table 1) and an ohmmeter. Clamp the thermistor to the top of the heat sink with a wooden clothes pin, so that the thermistor leads point upward. Wait a minute or so for the thermistor temperature to stabilize, and then measure its resistance. An example temperature calculation is shown below the table. Compare your thermistor temperature measurement to that read by one of the infrared thermometers (see a TA or Dr. Grady).

Table 1: Resistance-Temperature Characteristics of GE MTC Thermistors, Negative Temperature Coefficient Thermistor Material Type D9.7A (source www.gesensinginspection.com/en/temperature.html)

Temp T - °C	RT/R(T=25 °C)	Temp T - °C	RT/R(T=25 °C)
0	3.28	60	0.249
5	2.55	65	0.208
10	1.993	70	0.1752
15	1.573	75	0.1482
20	1.250	80	0.1258
25	1.000	85	0.1073
30	0.806	90	0.0919
35	0.653	95	0.0790
40	0.532	100	0.0682
45	0.437	105	0.0591
50	0.360	110	0.0513
55	0.298		

Example calculation: If the resistance of a 1kΩ (at 25°C) thermistor is 360Ω, then the thermistor temperature is 50°C. If the thermistor resistance is 1993Ω, then the thermistor temperature is 10°C. Use linear interpolation between points. Unlike most materials, the resistance of a thermistor decreases with temperature. This property is used to trigger relays for hot warning lights and motor overheat protection.

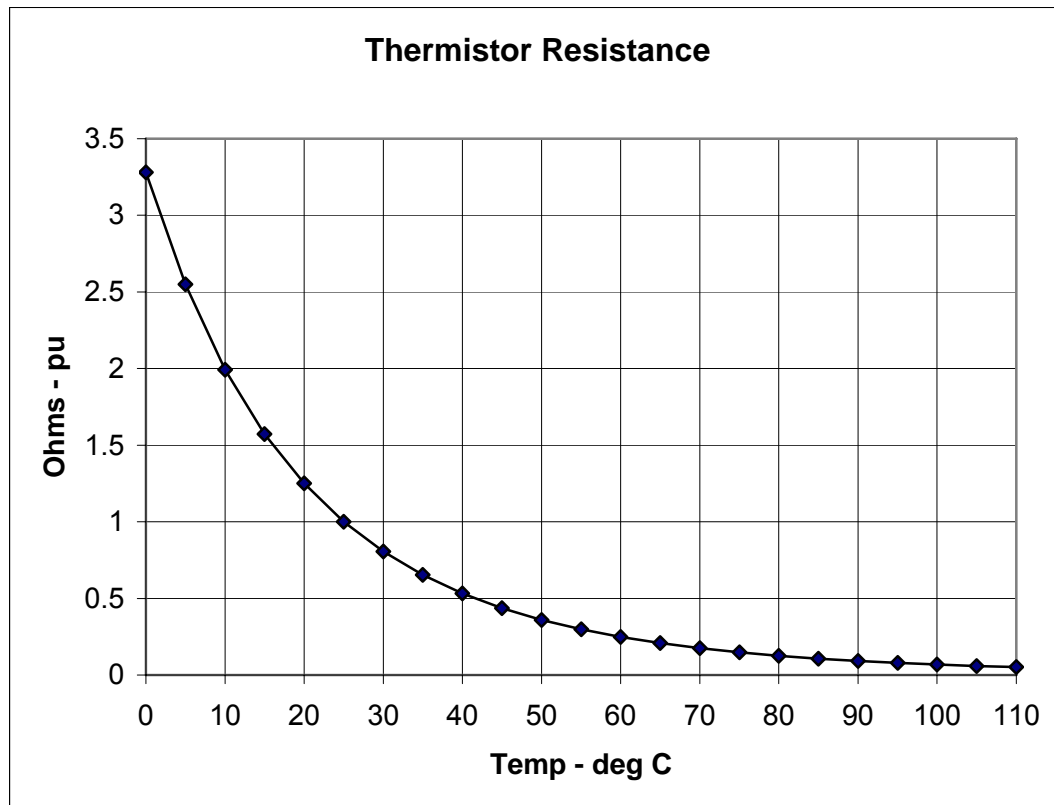

- C. **10 Ω Load Resistance.** Connect one 10 Ω or two series 5 Ω , 225W, power resistors to your DBR's output. Raise the variac to hold V_{ac} constant. Use a multimeter to measure V_{ac} , I_{ac} (using the voltage across the **body** of your 0.01 Ω input resistor, excluding any extra wiring and contact resistance), V_{dc} , and I_{dc} (using the **body** of your 0.01 Ω output resistor). Compute $P_{dc} = V_{dc} \cdot I_{dc}$. View V_{dc} on an oscilloscope, and use the oscilloscope to measure V_{peak} and the peak-to-peak ripple voltage.
- D. **5 Ω Load.** Repeat Step C, with one 5 Ω or two parallel 10 Ω , 225W resistors.
- E. **Diode Losses and Heat Sink Performance.** For the load condition in Step D, use an oscilloscope to view the forward voltage across one of the diodes in the bridge module. As illustrated on the following page, estimate the average forward voltage drop on the diode during its conduction interval.

EE462L, Power Electronics, Capacitor Filtered Diode Bridge Rectifier
Version Sept. 2, 2011

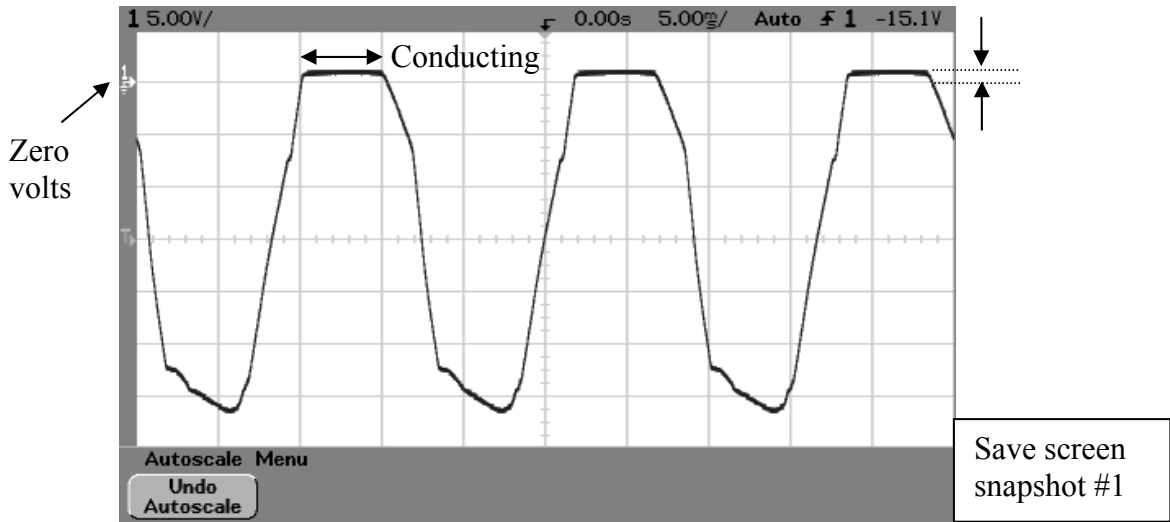
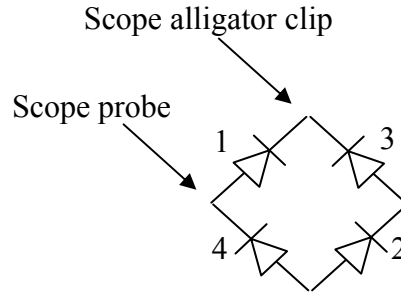

Example for Step E. Connecting the oscilloscope across one diode will display the forward voltage across one diode during conduction. The forward voltage drop is seen to be approximately 1V.

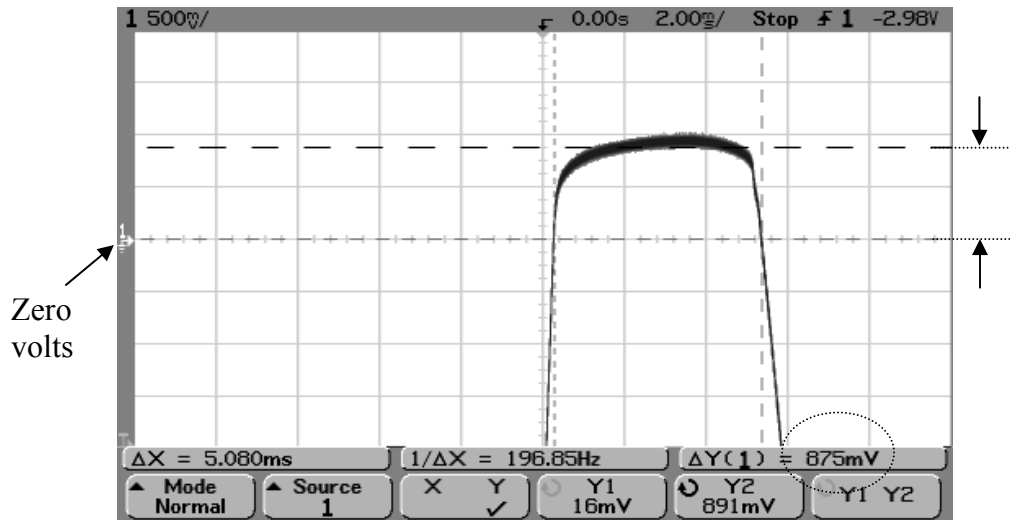

Example for Step E. “Zooming-in” on the forward voltage and using the cursors gives a more accurate reading of the average forward voltage drop. In this case, the average is approximately 0.875V

EE462L, Power Electronics, Capacitor Filtered Diode Bridge Rectifier

Version Sept. 2, 2011

Next, use the oscilloscope to estimate the average ac current during one conduction pulse. Note – each diode sees one pulse of the ac current, once per cycle. Use the voltage and current averages to compute total average power loss on all four diodes as shown in (6) in the following figure.

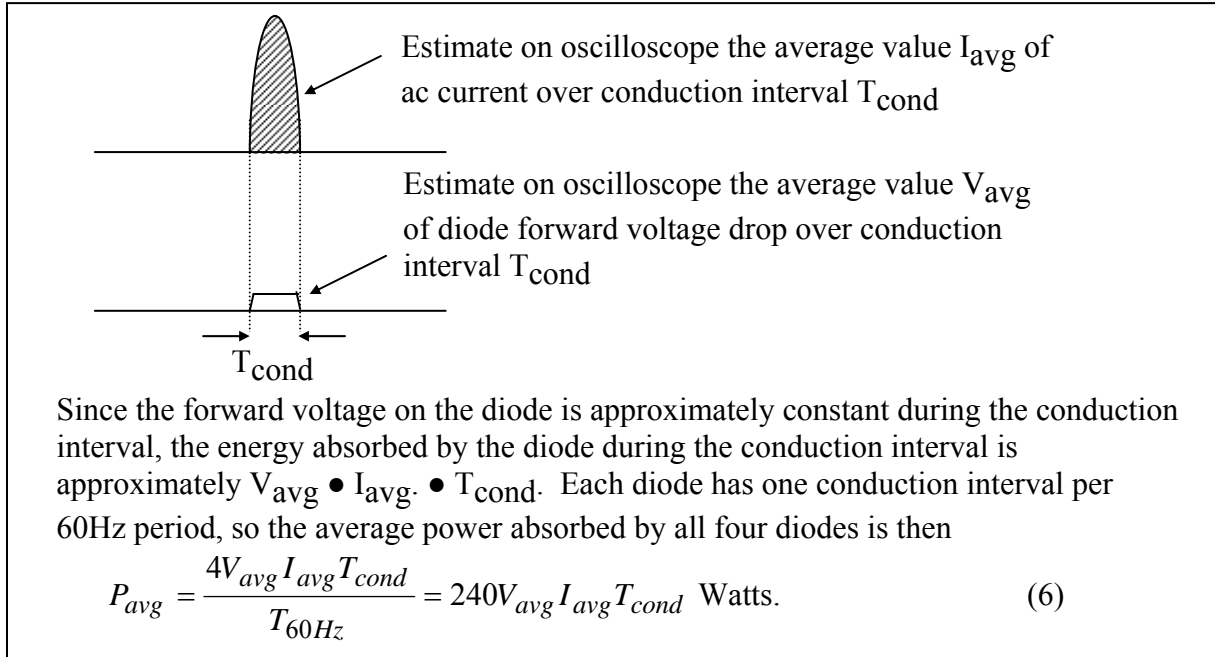

Example for Step E. The AC current is viewed by observing the voltage across the 0.01Ω input current sensing resistor. Use the averaging feature of the scope to “denoise” the waveform and display it properly. Then, “freeze” the waveform. By adjusting the cursors, the period is seen to be approximately 16.72ms (i.e., $1 \div 60\text{Hz}$).

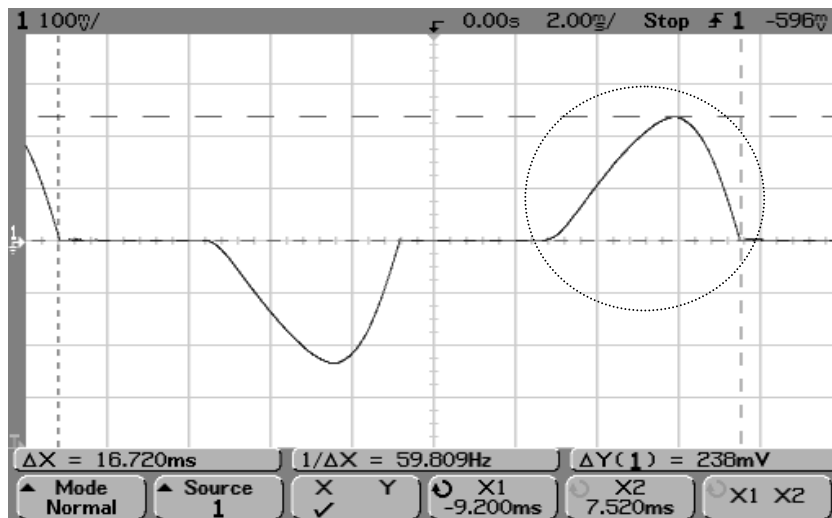

Save screen snapshot #2

EE462L, Power Electronics, Capacitor Filtered Diode Bridge Rectifier

Version Sept. 2, 2011

One pulse of the AC current passes through each diode pair. In the example shown above, the peak of the voltage pulse across the 0.01Ω current shunt is 238mV , corresponding to $0.238\text{V} \div 0.01 = 23.8\text{A}$. The conduction time is 4.68ms . Because the pulse is approximately triangular, the average value during conduction is about $23.8 \div 2 = 11.9\text{A}$. A handy fact to remember is that with a 0.01Ω current shunt, 10mV corresponds to 1A .

After the circuit has been operating with the 5Ω load for at least five minutes, use a thermistor to measure the temperature of the heat sink. Compute the $^{\circ}\text{C}$ rise above ambient (note – ambient temperature was measured in Step B). Use the power loss from (6) and the temperature rise to compute the thermal resistance coefficient of the heat sink (in $^{\circ}\text{C}$ rise per Watt). The manufacturer's catalog thermal resistance value is approximately $2^{\circ}\text{C}/\text{W}$. Compare your thermistor temperature measurement to that shown by one of the infrared thermometers.

- F. **Plot I_{dc} vs. V_{dc} for Steps A, C, and D.** Put I_{dc} on the vertical axis, and V_{dc} on the horizontal axis.
- G. **Plot Measured $\%V_{\text{ripple}}$ for Steps A, C, and D.** Put $\%V_{\text{ripple}}$ on the vertical axis, and P_{dc} on the horizontal axis.
- H. **Plot Theoretical $\%V_{\text{ripple}}$ for Steps A, C, and D.** Use (5) with the measured values of V_{peak} and P (i.e., $P = V_{\text{dc}} \cdot I_{\text{dc}}$). Superimpose the results of (5) on the plot from Step G.
- I. **Measurements vs. Theory.** Comment on the differences between Steps G and H.
- J. **Estimate the Capacitance of the Electrolytic Capacitor.** Switch off the transformer and connect the scope probes across the 5Ω power resistor. Switch on the transformer. Set the scope vertical axis to $10\text{V}/\text{div}$, and the time axis to $100\text{msec}/\text{div}$. Adjust the scope so that the trace and ground reference are both visible (see below). Set the trigger mode to “normal,” and the trigger edge to “downward.” Then, switch off the transformer. You should see a response similar to that shown below. The exponential decreases by the factor $e^{-1} = 0.368$ in one time constant $\tau = RC$ seconds. Use the graph, and the known R , to estimate C .

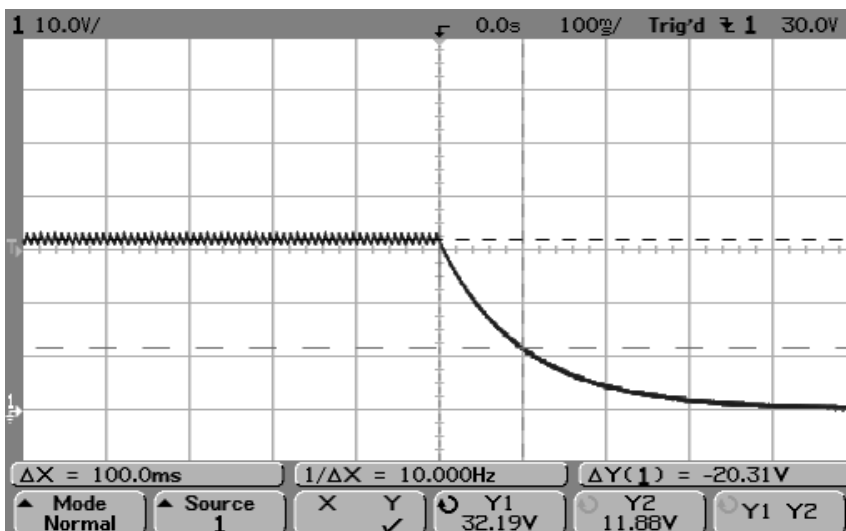

Save screen
snapshot #3

EE462L, Power Electronics, Capacitor Filtered Diode Bridge Rectifier

Version Sept. 2, 2011

Parts List

- Five 2-terminal, 30A terminal blocks (Molex/Beau, Mouser #538-38211-0102)
- 200V, 35A diode bridge rectifier module (Vishay Semiconductor, Mouser #625-GBPC3502-E4), (note + and – terminals, and be careful with polarity!)
- One 3" by 4" heat sink (Wakefield 641K, Mouser #567-641-K, or DigiKey # 345-1053-ND). 2°C per Watt. Hole drilled with 5/32" bit, and de-burred to smooth surface, to fit 1½" steel corner bracket.
- 18000µF, 50V Mallory computer-grade electrolytic capacitor (Mouser #539-CGS50V18000), with screws and lockwashers (note + and – terminals, and be careful with polarity!). Alternatively, use 16000µF, 50V capacitors.
- Vertical mounting clamp with tightening screw for capacitor (For 18,000µF, use Mallory VR8, Mouser #539-VR8; for 16,000µF, use Mallory VR3, Mouser #539-VR3), or equivalent. (Clamp uses #6-32 x ½" to 1" machine screw and nut)
- Toggle switch, SPST, 125V, 15A with quick connect terminals (Mouser #633-S1F-RO)
- GE NTC thermistors, 1kΩ at 25°C (Mouser #527-2004-1K). Alternately, use 500Ω or 2kΩ.
- Wooden clothes pin to hold the thermistor firmly against heat sink fins to make a good thermal contact.
- LED indicator light and assembly, T-1¼ (5mm), approx. 10ma (Mouser #358-R9-104L-12-R)
- 1½" steel corner bracket for mounting the heat sink (Stanley 30-3170, Home Depot).
- 2" steel corner bracket for mounting the switch (Stanley 30-3300, Home Depot). Hole in bracket enlarged with 15/32" drill bit to fit the toggle switch.
- 1" steel corner bracket for mounting LED. Hole in bracket enlarged with 5/16" drill bit to fit the LED indicator assembly.
- Two 0.01Ω, 3W metal element current sensing resistors (IRC Advanced Film Division, Mouser #66-LOB3R010JLF), or (Ohmite, Digikey #630HR010-ND) (in student parts bin)
- 2kΩ, 2W resistor (in student parts bin)
- 3.3kΩ, 1W resistor (in student parts bin)
- 1" x 6" wood (approx. 12" long piece)

EE462L, Power Electronics, Capacitor Filtered Diode Bridge Rectifier
Version Sept. 2, 2011

#8-32, 1" machine screw, flat washer, split washer, and hex nut for mounting DBR module to heat sink

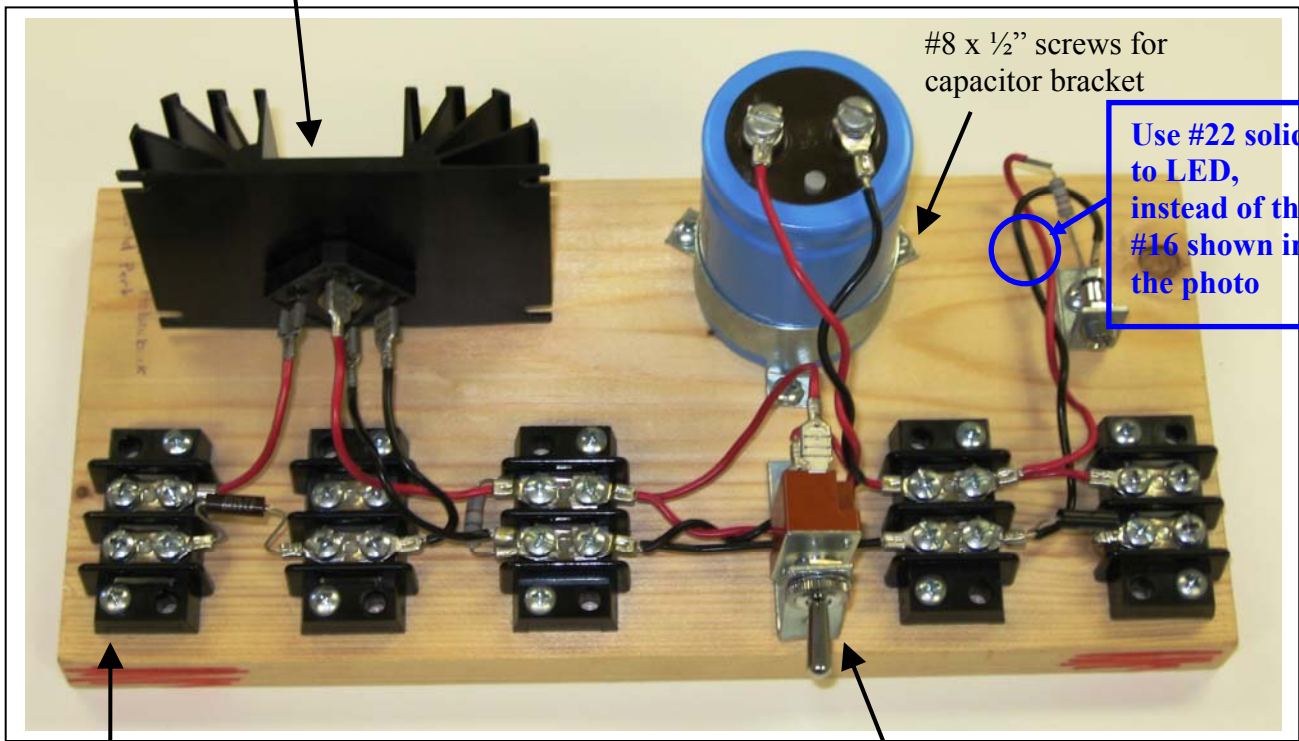

#8 x 1/2" screws for capacitor bracket

Use #22 solid to LED, instead of the #16 shown in the photo

#8 x 3/4" screws for terminal blocks

#8 x 1/2" screws for corner brackets

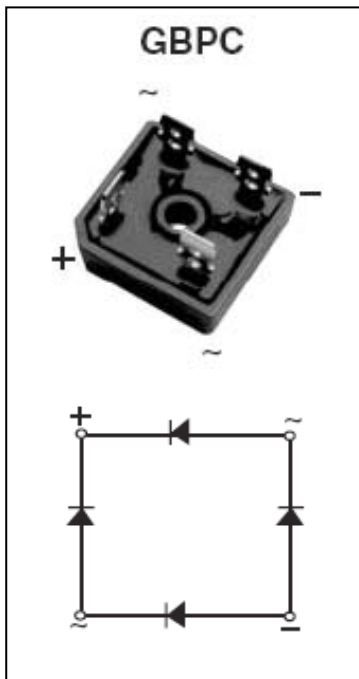

200V, 35A Vishay Semicondutor DBR Module

Measuring the temperature on the backside of a solar panel

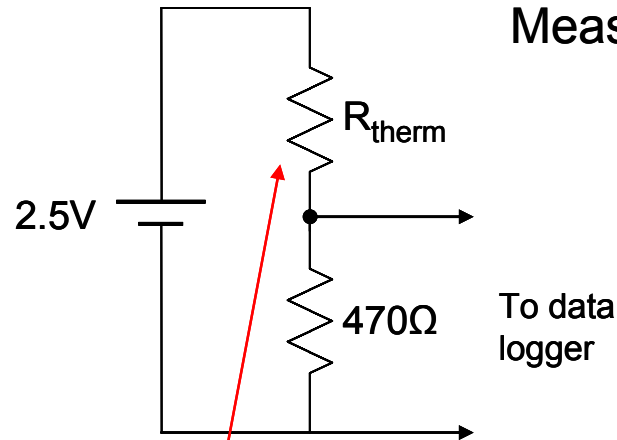

- Thermistor in series with 470Ω resistor
- Series combination energized by 2.5Vdc
- The voltage across the 470Ω resistor then changes with temperature as shown below

Excel curve fit. Coefficients entered into data logger.

