

Name _____

ELC 4383 – RF/Microwave Circuits I

Fall 2018

Final Exam – December 11, 2018

Open Book/Open Notes

2 hours

1. The exam is open-book/open-notes.
2. A calculator may be used to assist with the test. No laptops or tablets are allowed. No cellular phones may be used in any way during the test. Unauthorized electronic device use will result in disqualification.
3. You must circle or box your answers to get full credit.
4. All work and steps toward a solution must be clearly shown to obtain credit.
5. Partial credit may be given provided that the grader can clearly follow your work to the extent that an understanding of the problem is demonstrated.
6. No collaboration is allowed on this examination. Only Dr. Baylis or a teaching assistant may be consulted for clarification.
7. You may attach extra sheets to the exam if necessary. Each page should contain your name, the problem number, and the page number for that problem.

Please sign the statement below. **YOU MUST SIGN THE STATEMENT OR YOU WILL GET A ZERO FOR THIS EXAMINATION!!!**

I hereby testify that I have neither provided or received information from unauthorized sources during the test and that this test is the sole product of my effort.

Signed _____

Date _____

PROBLEM 1 (15 points): Design a single-section coupled-line coupler with a coupling of 8 dB, a system impedance of 50 ohms, and a center frequency of 5 GHz. If the coupler is to be made in microstrip with $\epsilon_r = 10$ and $d = 1.1$ mm, answer the following questions.

(a) Find C (as used in the equations to find the even and odd mode characteristic impedances; not in dB) (1 point).

(b) Find the even-mode characteristic impedance, Z_{0e} (4 points).

(c) Find the odd-mode characteristic impedance, Z_{0o} (4 points).

(d) Find W , the width of the microstrip lines (3 points).

(e) Find S , the separation of the microstrip lines (3 points).

PROBLEM 2 (20 points): Design a bandpass, 0.5 dB equal ripple, lumped-element filter having a center frequency of 3.3 GHz and a bandwidth of 10 percent. The characteristic impedance is 50Ω . Choose the minimum number of sections such that the attenuation is greater than 10 dB at 3.522 GHz. Use a series network to represent the filter element closest to the source. Draw the filter with all capacitor and inductor values, as well as the load impedance, clearly labeled.

(Extra workspace on next page)

(Extra workspace for Problem 2)

PROBLEM 3 (15 points): Design a stepped-impedance, maximally flat low-pass filter having a cutoff frequency of 2.8 GHz and an attenuation of at least 20 dB at 4.76 GHz. Use a reference impedance of $Z_0 = 50 \Omega$. The highest practical line impedance is 120Ω , and the lowest is 15Ω . Use a high-impedance line for the first section (closest to the source) and use the minimum number of sections capable of meeting the attenuation requirement, according to the appropriate figure in the textbook. Draw a schematic for the filter with the electrical length and characteristic impedance of each transmission line section clearly labeled. Clearly specify the necessary load resistance value in Ohms.

PROBLEM 4 (15 points): Consider a loaded series resonant RLC circuit. The resonator consists of a $2\ \Omega$ resistor, a $15\ \text{nH}$ inductor, and an $18\ \text{pF}$ capacitor, all in series. The load is $50\ \Omega$.

(a) What is the resonant frequency (in MHz) (5 points)?

(b) What is the unloaded Q (5 points)?

(c) What is the loaded Q (5 points)?

PROBLEM 5 (20 points): A mixer contains a diode with the following parameters: $C_j = 0.3$ pF, $R_s = 0.4$ Ω , $I_s = 90$ μ A, and $L_p = C_p = 0$. The mixer is designed to receive an RF input signal at a frequency of 2.4 GHz and down-convert it to an IF signal at 400 MHz. Use $\alpha = 1/(25$ mV).

(a) Compute the open-circuit voltage sensitivity at 2.4 GHz for $I_0 = 10$ mA (4 points).

(b) If the local oscillator frequency is higher than the RF frequency, give the LO frequency and the image frequency (4 points).

(Problem 5 continued on next page.)

For parts (c) and (d), assume that the following power levels are measured at the ports of a frequency-conversion system containing the mixer and necessary filtering:

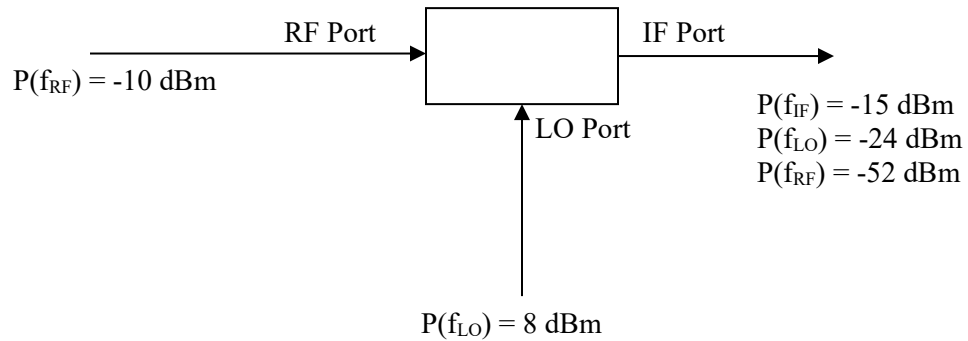

(c) Calculate the conversion loss (4 points).

(d) Calculate the LO-to-IF isolation (4 points).

(e) Calculate the RF-to-IF isolation (4 points).

PROBLEM 6 (15 points): Use single-stub impedance matching techniques with the Smith Chart on the following page to provide $Z_{in} = 50 \Omega$. Use an open-circuit stub and find d and l in terms of λ . Use $Z_0 = 50 \Omega$ for all transmission lines.

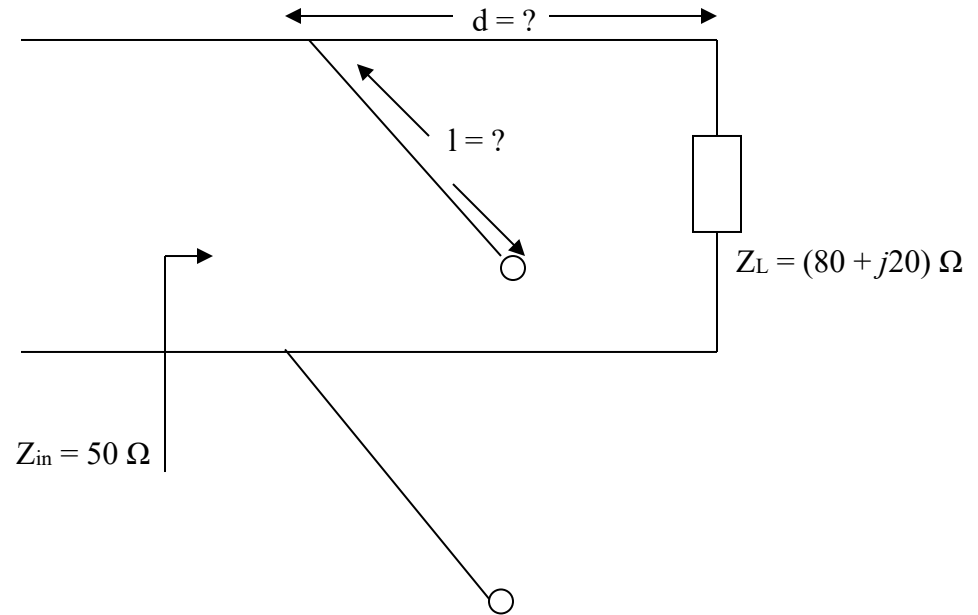

The Complete Smith Chart

Black Magic Design

